

TENTH WORLD CONGRESS ON THE THEORY OF MACHINE AND MECHANISMS

Oulu, Finland, June 20 – 24, 1999

A FORCE-UPDATED KINEMATIC VIRTUAL VIEWING SYSTEM WITH APPLICATION TO NUCLEAR POWER PLANT MAINTENANCE

Marco A. Meggiolaro, Peter C. L. Jaffe, Karl Iagnemma and Steven Dubowsky
Department of Mechanical Engineering
Massachusetts Institute of Technology
Cambridge, MA 02139

Abstract

Important nuclear maintenance tasks, such as the steam generator nozzle dam placement, could be most effectively done by robotic systems. However, restricted teleoperator visibility and lack of absolute accuracy make such tasks very difficult to perform using conventional robotic control technology. In this paper, successful nozzle dam placement is achieved through a 3-D virtual viewing system which includes contact force information.

Keywords: contact forces, Base Sensor Control, virtual viewing, nuclear maintenance, robotics

1 Introduction

Most nuclear power plant maintenance tasks are currently performed by humans. Some of these tasks, including the important placement of the steam generator nozzle dam, require workers to be exposed to dangerously high levels of radiation [Zezza 1985]. To avoid human exposure, robotic systems have been proposed and evaluated for such tasks. However, in a number of cases, the robotic technology was not adequate. In this paper, a robotic system for successfully placing a nuclear power plant steam generator nozzle dam is presented. Nozzle dam placement is a challenging and typical nuclear maintenance robotic task. Restricted teleoperator visibility and tight geometric tolerances between the nozzle dam and its receptacle make the task very difficult to perform using conventional robotic control technology. Our approach consists of a virtual viewing system based on 3-D kinematic models combined with real-time contact force measurements. Laboratory experiments show that successful nozzle dam placements could be performed using the visualization system with a conventional Schilling hydraulic manipulator.

2 Task and Experimental System

2.1 A Representative Task

The control system presented in this paper has been developed for a nuclear maintenance task. In order for workers to inspect and repair a nuclear power plant's steam generator, two large pipes (1 meter in diameter) must be sealed with a device called a nozzle dam. The nozzle dam weighs 60 kg and must be inserted into a nozzle ring with clearances of approximately one millimeter. Workers enter the steam generator through a 0.4 meter in diameter portal and receive high doses of radiation while securing the nozzle dam. Hence, performing this task with a

robotic manipulator would be very desirable. A simulated robotic nozzle dam placement can be seen in Figure 1a, where the manipulator is moving the nozzle dam side plate into its position in the nozzle ring. The center plate is then inserted within the side plate as shown in Figure 1b.

Past attempts to place the nozzle dam with a teleoperated manipulator have taken too long because of the combination of poor operator visibility and the lack of manipulator repeatability. Tens of thousands of dollars of revenue are lost each hour the nuclear power plant is offline. In this paper, both the operator interface and manipulator repeatability are improved to make automated nozzle dam insertion practical.

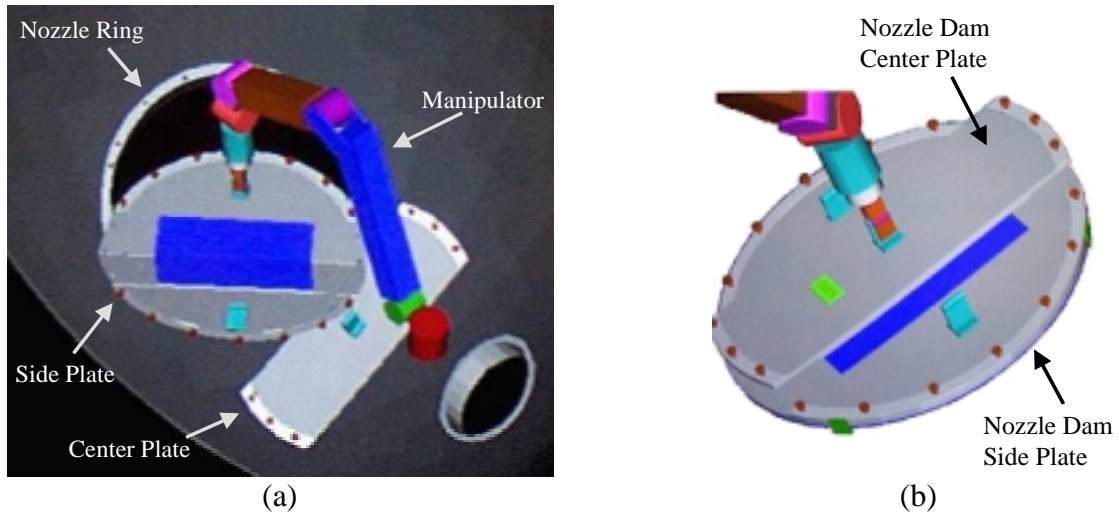

Figure 1 - Simulated Robotic Nozzle Dam Task

2.2 Experimental System

Figure 2 shows the laboratory system used to emulate one of the critical parts of the nozzle dam placement task. Figure 3 shows an 18 kg nozzle dam center plate and a variable tolerance receptacle used to emulate the insertion of the nozzle dam center plate into the side plate. The receptacle is mounted in the workspace so that the manipulator configurations are representative of the actual task. A handle on the center plate provides a repeatable grip for the manipulator. The manipulator chosen for this task is a Schilling Titan II six DOF hydraulic robot capable of handling payloads in excess of 100 kg. This manipulator is widely used in nuclear maintenance.

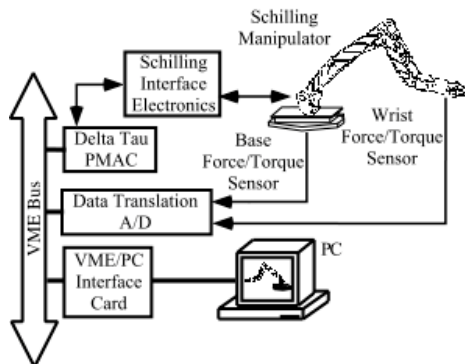

Figure 2 - System Hardware Configuration

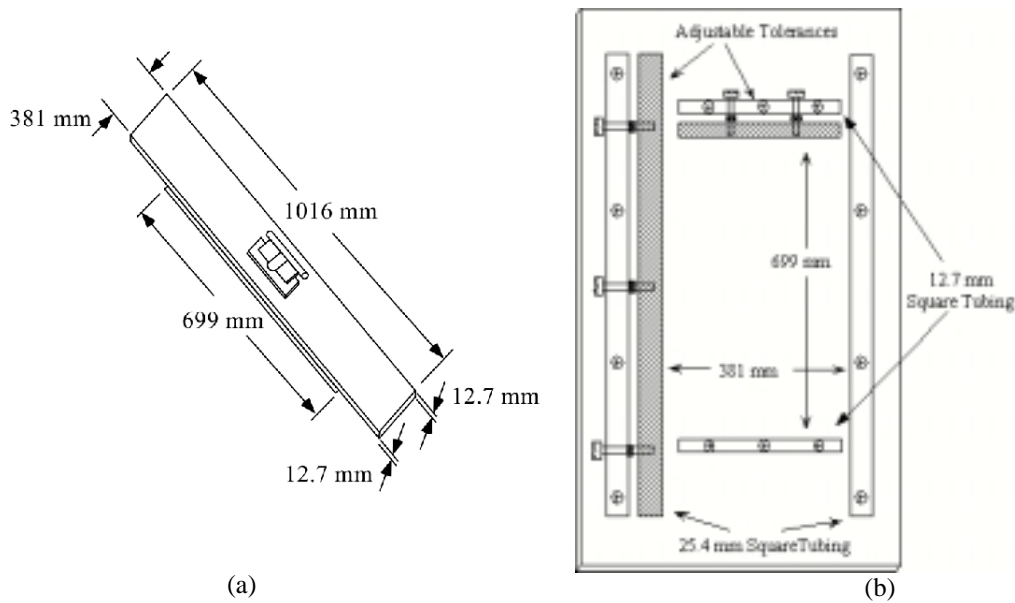

Figure 3 – Nozzle Dam Center Plate (a) and Variable Tolerance Receptacle (b)

Joint resolver signals, standard on the Schilling, are converted to quadrature encoder waveforms using a Delta Tau Data/PMAC controller design. Both base and wrist force/torque sensors are sampled by a Data Translation 16-bit ADC. A 300 MHz PC handles the control loop computations and graphical user interface.

In order to perform the nozzle dam placement task, a custom teleoperator software package has been developed. The system contains 3-D kinematic models of the manipulator and the workspace, reflecting the actual system configuration based on the joint resolvers. The interface provides improved operator visibility by allowing “virtual viewing” of physically obscured regions using “virtual cameras” [Cho, 1998]. The virtual cameras also allow for magnifying the mating edges in order to aid in teleoperated insertion. A Cartesian end-point controller is embedded in the software to provide full teleoperation functionality. Figure 4 shows the manipulator and experimental testbed for both real and simulated systems.

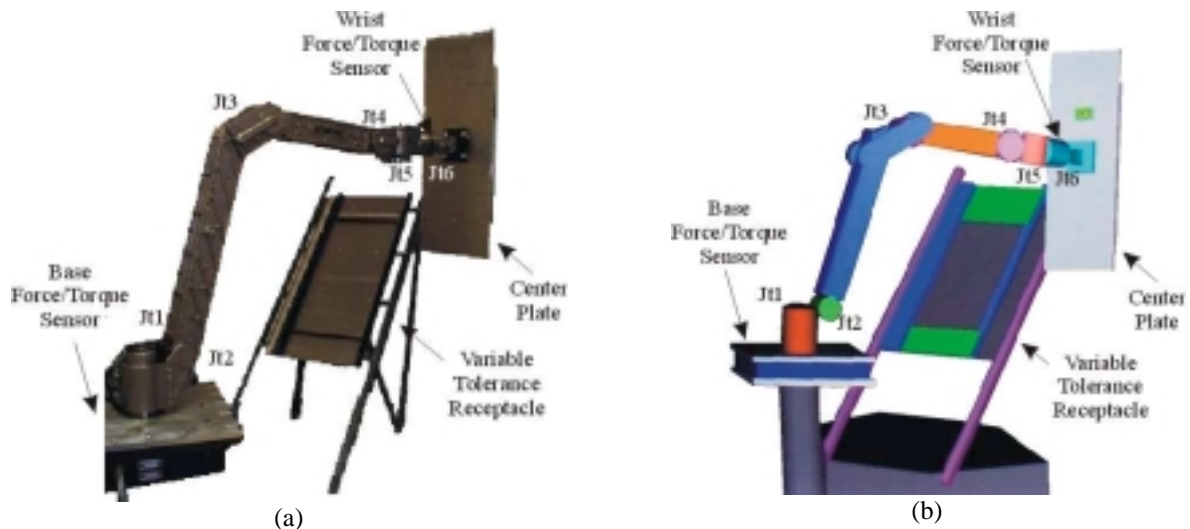

Figure 4 – Real (a) and Simulated (b) Experimental System

The tight tolerances of the task require the teleoperator to command fine position adjustments. However, the strong manipulators required for such tasks lack repeatability, mainly due to high friction in their joints and actuators. Base Sensor Control (BSC) [Morel et al. 1996] is implemented to improve the manipulator repeatability through accurate joint torque control. Furthermore, manipulator end-point errors due to geometric distortions of the system and elastic deformations degrade the manipulator's accuracy. Here a method called Geometric and Elastic Error Compensation (GEC) is used to greatly reduce these errors [Meggiolaro et al. 1998].

However, even with these key enabling technologies, some geometric uncertainty still exists between the modeled and real environments making teleoperation difficult to perform. To overcome this, the contact forces between the center plate and its receptacle are estimated from wrist sensor and task geometry and displayed to the teleoperator.

3 Contact Force Estimation

Contact force information between the manipulator end-effector and the environment is fundamental for placement tasks with small tolerances [Bicchi 1993]. However, a wrist force/torque sensor provides limited information, namely 3 force and 3 torque components, while each contact point is associated with 9 unknowns: the coordinates of the contact point location and the contact wrench components. In the case where there is only one contact point with the environment and where the contact torque is zero, it is possible to calculate the contact information required for control. This can be obtained from wrist force torque information combined with knowledge of the geometry of the mating parts.

Figure 5 shows a plate attached to the end-effector of a manipulator. The force exerted by the environment on the plate, \mathbf{F}_c , and the contact location with respect to the wrist force/torque sensor, \mathbf{r}_c , can be calculated from:

$$\mathbf{F}_c = \mathbf{F}_s, \quad \mathbf{r}_c = \frac{\mathbf{F}_s \times \mathbf{M}_s}{\|\mathbf{F}_s \times \mathbf{M}_s\|} \frac{\|\mathbf{M}_s\|}{\|\mathbf{F}_s\|} + \alpha \mathbf{F}_s \quad (1)$$

where \mathbf{F}_s and \mathbf{M}_s are respectively the forces and moments measured from the wrist sensor, and α is an arbitrary constant. Note that Equation (1) has an infinite number of solutions, since two equal forces along the same line of action result in the same wrist sensor reading, see Figure 5.

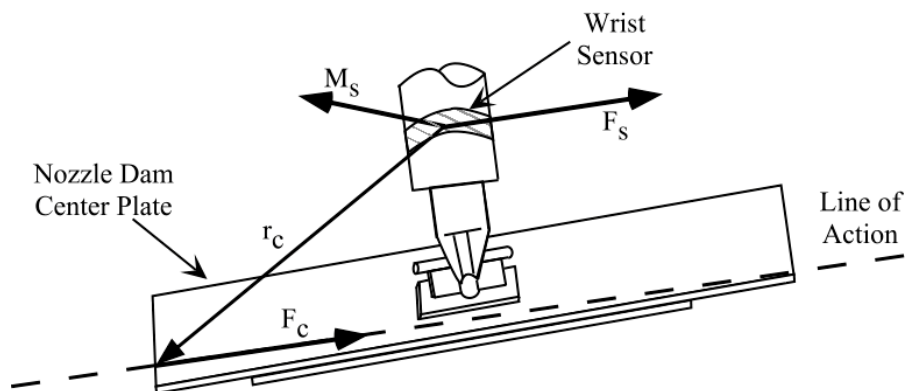

Figure 5 - Contact Force and Wrist Force/Torque Sensor Readings

In order to obtain a unique solution to Equation (1), the plate geometry must be considered. Defining Γ as a vector function representing the plate surface in the wrist sensor coordinates, then α is determined by calculating the intersection between the line of action of the contact force and the plate surface Γ ,

$$\alpha \mathbf{F}_s \equiv \Gamma - \frac{\mathbf{F}_s \times \mathbf{M}_s}{\|\mathbf{F}_s \times \mathbf{M}_s\|} \frac{\|\mathbf{M}_s\|}{\|\mathbf{F}_s\|} \quad (2)$$

Due to the nature of contact forces, which are directed toward the interior of the plate, the calculated values of \mathbf{r}_c must also satisfy

$$\mathbf{n}(\mathbf{r}_c) \cdot \mathbf{F}_c \leq 0 \quad (3)$$

where $\mathbf{n}(\mathbf{r}_c)$ is the normal vector to the plate surface at the point \mathbf{r}_c .

If Γ represents a convex surface, then the solution to Equations (2) and (3) is either unique or non-existent. Otherwise, multiple solutions exist for certain configurations. For the particular case shown in Figure 5, Γ is not convex, but it can be represented by a set of simple equations of the planes of the plate. Frequently, as in the case of the nozzle dam insertion plate, a single solution for the contact point can be determined by considering the contact friction as well as the geometry of the mating parts.

Based on Equations (2) and (3) and models of the plate and receptacle, a force vector and contact point is calculated from the measured wrist wrench and displayed to the teleoperator. Figure 6 summarizes how a force-updated operator interface is combined with the high accuracy BSC position controller to perform the nozzle dam placement task.

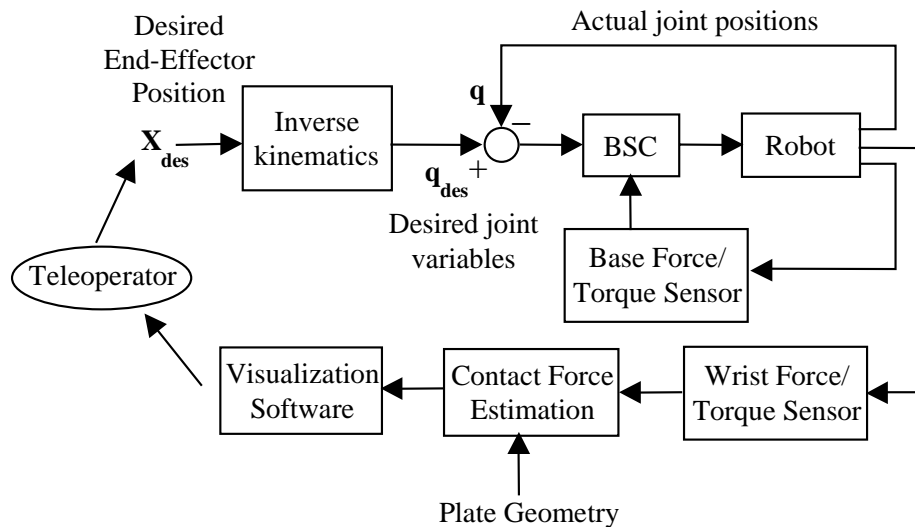

Figure 6 - Base Sensor Control and Contact Force Estimation Scheme

4 Experimental Verification

Representative nozzle dam placements were conducted to demonstrate the effectiveness of the force-updated virtual viewing system. Figure 7 shows a sequence of screenshots from the teleoperator display during a typical placement. Each figure shows the center plate contacting the mating receptacle as well as visual feedback of the estimated contact force. The contact vector identifies misalignments in the insertion process, providing the necessary information to command small corrective motions.

Figure 7a suggests translational motions are necessary to align the plate. The next four screenshots shown in Figure 7 indicate rotational alignment errors. Finally, the contact force in Figure 7f suggests that successful placement was achieved.

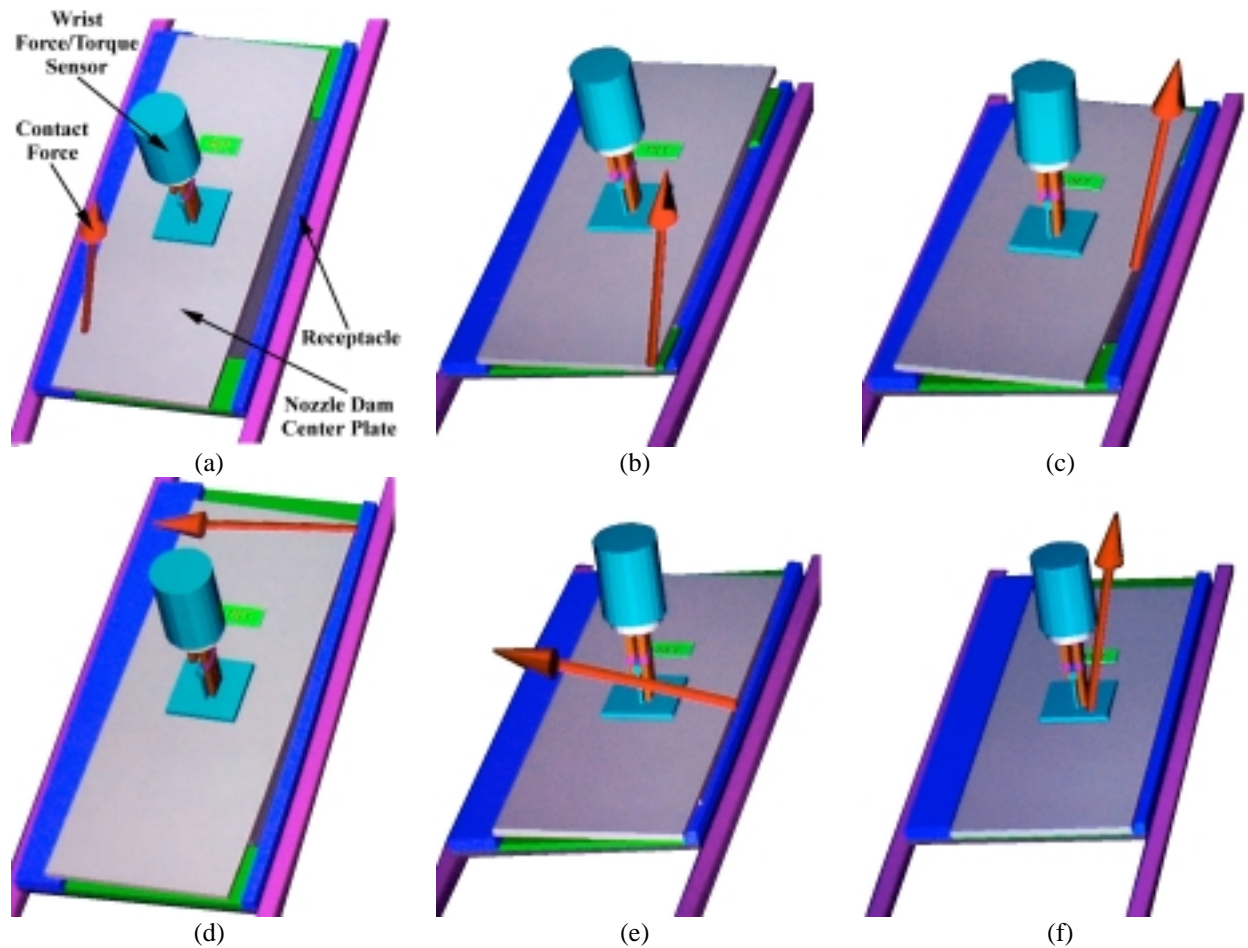

Figure 7 – Typical Placement Steps Using Contact Force Visualization

The experimental insertions show that the force-updated virtual viewing system outlined in Figure 6 allows a conventional hydraulic manipulator to successfully perform the nozzle dam placement task. This approach is made practical by the means of BSC and GEC Control.

5. Conclusions

In this paper, a robotic visualization system for successfully placing a nuclear power plant steam generator nozzle dam is presented. A teleoperator software package has been developed containing 3-D kinematic models of a Schilling Titan II hydraulic manipulator and the workspace. Contact force information between the center plate and its receptacle is obtained from wrist sensor wrench measurements and geometric models of the mating geometries. The contact force vector is displayed to the teleoperator and allows for real-time recognition of misalignments in the insertion process. This aids in successfully achieving insertion using a position control algorithm. Experiments demonstrated that the nozzle dam placement task can be achieved by combining a high repeatability position controller, such as BSC and GEC, and a force-updated operator interface.

Acknowledgments:

The assistance and encouragement of Dr. Byung-Hak Cho of the Korean Electric Power Research Institute (KEPRI) and Mr. Jacques Pot of the Electricité de France (EDF) in this research is most appreciated, as the financial support of KEPRI and EDF.

References:

Bicchi, A., Salisbury, J., Brock, D., Contact Sensing from Force Measurements, *The International Journal of Robotics Research*, Vol. 12, No. 3, 1993, pp 249-262.

Cho, B., Simulation Studies on Robot System Applied to Nozzle Dam Installation, KEPRI Technical Memo, 1998.

Iagnemma, K., Morel, G. and Dubowsky, S., A Model-Free Fine Position Control System Using the Base-Sensor: With Application to a Hydraulic Manipulator, *Symposium on Robot Control, SYROCO '97*, Vol. 2, 1997, pp 359-365.

Meggiolaro, M., Mavroidis, C. and Dubowsky, S., Identification and Compensation of Geometric and Elastic Errors in Large Manipulators: Application to a High Accuracy Medical Robot, *Proceedings of the 1998 ASME Design Engineering Technical Conference*, Atlanta, 1998.

Meggiolaro, M., Jaffe, P. and Dubowsky, S., "Achieving Fine Absolute Positioning Accuracy in Large Powerful Manipulators", submitted to the *IEEE International Conference on Robotics and Automation (ICRA'99)*, Detroit, 1999.

Morel, G. and Dubowsky, S., The Precise Control of Manipulators with Joint Friction: A Base Force/Torque Sensor Method, *Proceedings of the IEEE International Conference on Robotics and Automation*, Vol. 1, 1996, pp 360-365.

Zeza, L., Steam Generator Nozzle Dam System", *Transactions of the American Nuclear Society*, Vol. 50, 1985, pp 412-413.